

14+
AGES

USER MANUAL

DRO-200

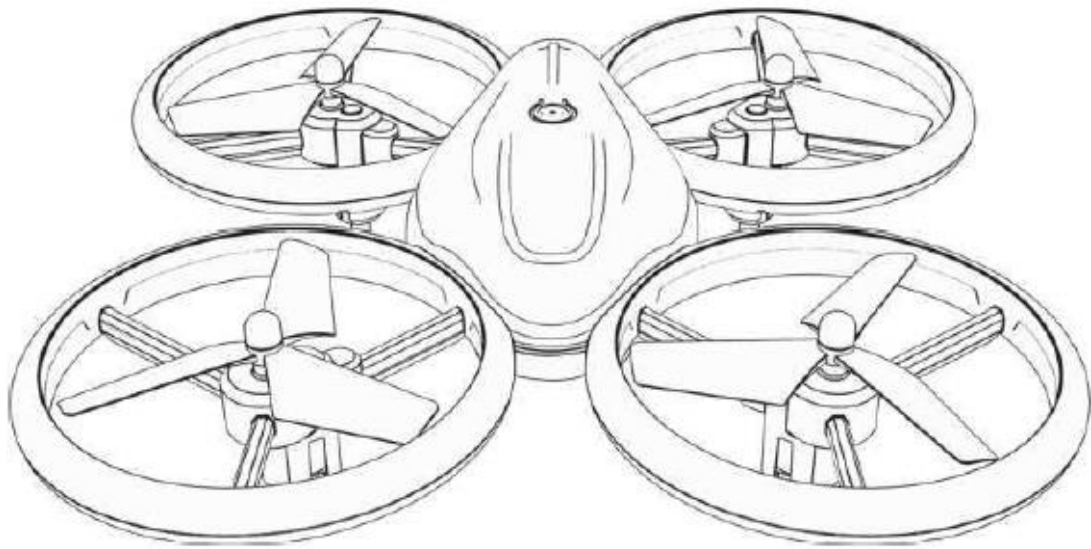

CONTROLS

One-button take-off/landing

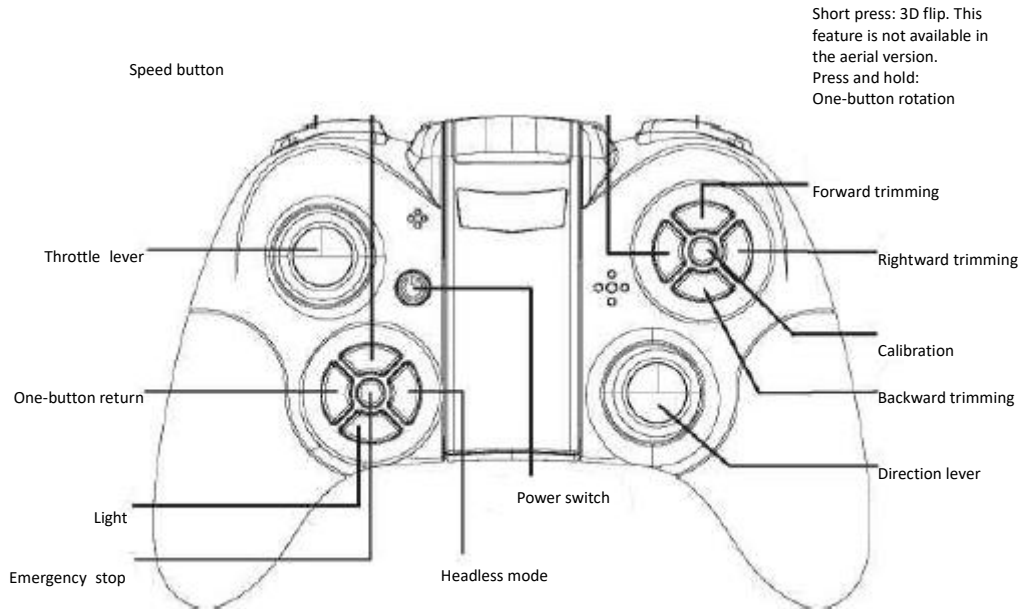

REMOTE CONTROL BATTERY INSTALLATION

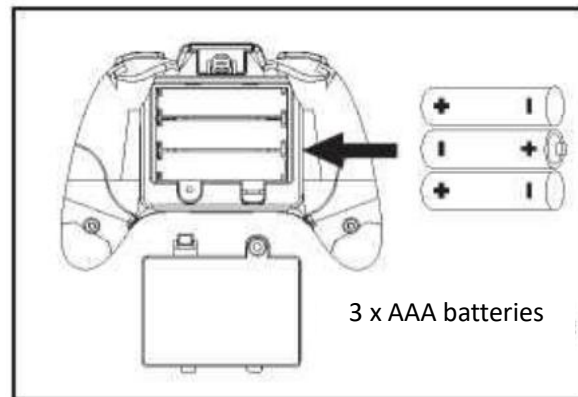

1: Use a screwdriver to remove the battery cover.

2: Install 3 x AAA batteries.

3: Replace the battery cover.

Note: Please follow the above illustration to install the batteries correctly.

AIRCRAFT BATTERY CHARGING

Insert the battery connector to the small end of the USB charger (ensure to connect tight and correct).

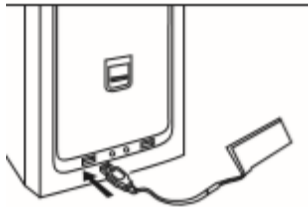

Use the USB charger to charge the aircraft battery pack. Charging time: about 100 minutes. When the battery is charged completely, disconnect the USB charger.

LED indicator USB

When the LED turns off the battery is charging. When the LED lights up, charging is completed. Charging must be supervised at all times.

PAIRING TRANSMITTER AND RECEIVER



Step 1

Set up the drone level and insert the Li-Po battery as shown in the illustration.



Step 2

Switch the drone on and do not move it until the LED changes from fast to slow flashing. Now the remote control can be paired with the drone.

To switch off, press and hold for 3 seconds, the LED turns off.

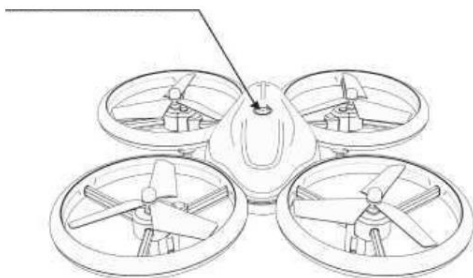

Step 3

Remove the drone battery after flying. Develop correct habits so as not to cause security risks.

Warning: If the battery is not removed from the drone for long period of time, it may be damaged due to over-discharge, or even become a fire

hazards.

Step 4

Turn off the transmitter. If transmitter is not to be used for a longer period of time, remove the batteries for storage.

Warning: If the batteries are left in the transmitter, potential leakage could occur which may damage the transmitter, and create a fire hazards.



If the transmitter is not to be used for a longer period of time, remove the battery for storage.

FLIGHT ADJUSTMENT AND SETTING

Read all instructions carefully before flying.

1. Place the aircraft in an open field with the tail pointing in your direction.
2. Practice to operate the throttle stick (as below illustration).

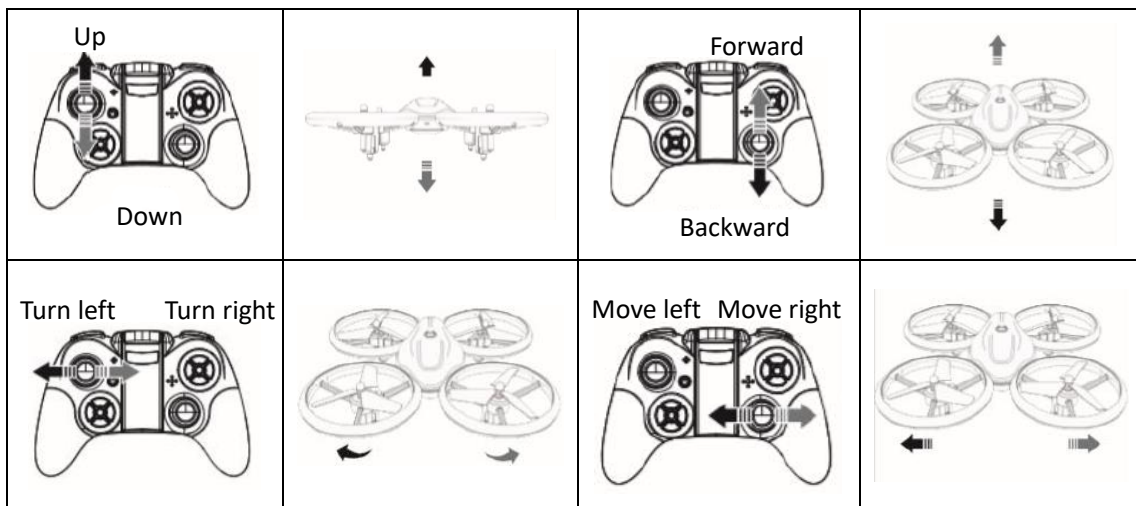

TRIM

Forward and backward trim.

1. When the drone flies forward/backward, press the backward/forward trim button to adjust.

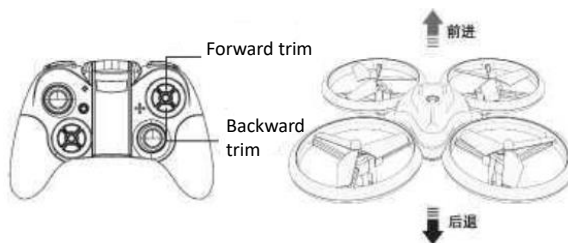

Left and right flying trim

2. When the drone flies left/right, press the right/left trim button to adjust.

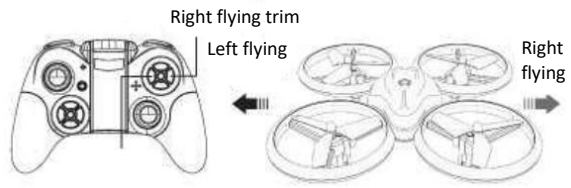

RECALIBRATION

If the trim buttons do not correct the problem, place the drone on a flat surface and recalibrate as follows.

Press the calibration button (see illustration).

Then the LED of the drone flashes quickly and the calibration is finished when the LED lights up.



HEADLESS MODE

Headless mode: When pressing the headless button, two beep tones are emitted.

(In this mode, the flying direction is still controlled by the controller.) No matter where the forward direction is, it is according to the operation of the controller. It is very simple and convenient. Press this button again, to exit headless mode; a beep tone is emitted.

One-button return

Within the controllable range, no matter where you are, after pressing this button, you will hear a beep tone and the drone will return to its original position. Move a joystick of the controller or press the button again to quit this mode.

HIGH SPEED AND LOW SPEED

Press this function button to change the speed of the drone during flight. There are 3 speed levels available: low, medium and high. When pressing the button, two beep tones will be heard and you changed to medium speed. Press the button again an three beep tones will be heard and you changed to high speed. Pressing the button a third time will return to low speed and a single beep tone is emitted...

3D FLIP

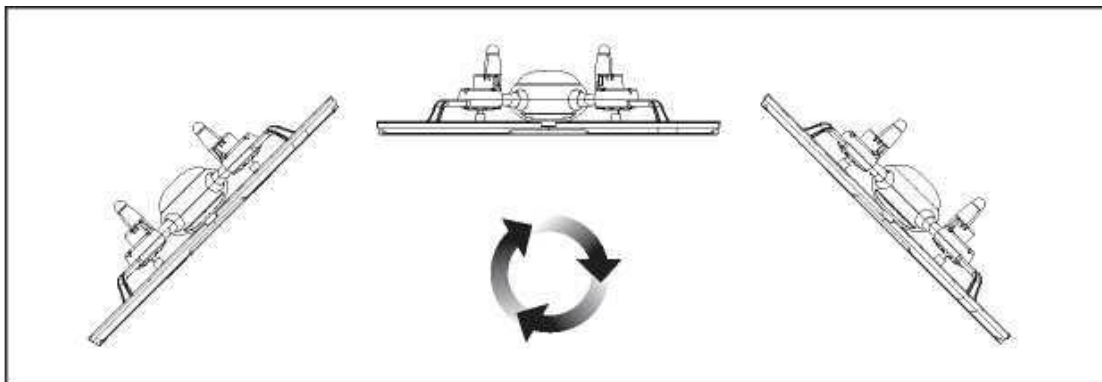

Press the flip button, and you will hear two beep tones. Move the right joystick to make the aircraft flip. When moving the joystick to the left, you will fly a left flip. Move it right to fly a right flip.

Please notice - All products are subject to change without any notice. We take reservations for errors and omissions in the manual.

ALL RIGHTS RESERVED, COPYRIGHT DENVER ELECTRONICS A/S

DENVER®

www.denver-electronics.com



Electric and electronic equipment and included batteries contains materials, components and substances that can be hazardous to your health and the environment, if the waste material (discarded electric and electronic equipment and batteries) is not handled correctly.

Electric and electronic equipment and batteries is marked with the crossed out trash can symbol, seen above. This symbol signifies that electric and electronic equipment and batteries should not be disposed of with other household waste, but should be disposed of separately.

As the end user it is important that you submit your used batteries to the appropriate and designated facility. In this manner you make sure that the batteries are recycled in accordance with legislature and will not harm the environment.

All cities have established collection points, where electric and electronic equipment and batteries can either be submitted free of charge at recycling stations and other collection sites, or be collected from the households. Additional information is available at the technical department of your city.

Hereby, Inter Sales A/S declares that the radio equipment type DRO-200 is in compliance with Directive 2014/53/EU. The full text of the EU declaration of conformity is available at the following internet address: www.denver-electronics.com and then click the search ICON on topline of website. Write model number: DRO-200. Now enter product page, and RED directive is found under downloads/other downloads.

Operating Frequency Range:

Max Output Power:

DENVER ELECTRONICS A/S

Omega 5A, Soefte

DK-8382 Hinnerup

Denmark

www.facebook.com/denverelectronics