

# DENVER®

## Bruksanvisning

Klokkeradio

CRL-330



[www.denver-electronics.com](http://www.denver-electronics.com)

Før du tar i bruk dette produktet, må du lese hele denne bruksanvisningen grundig.

# Produktinformasjon

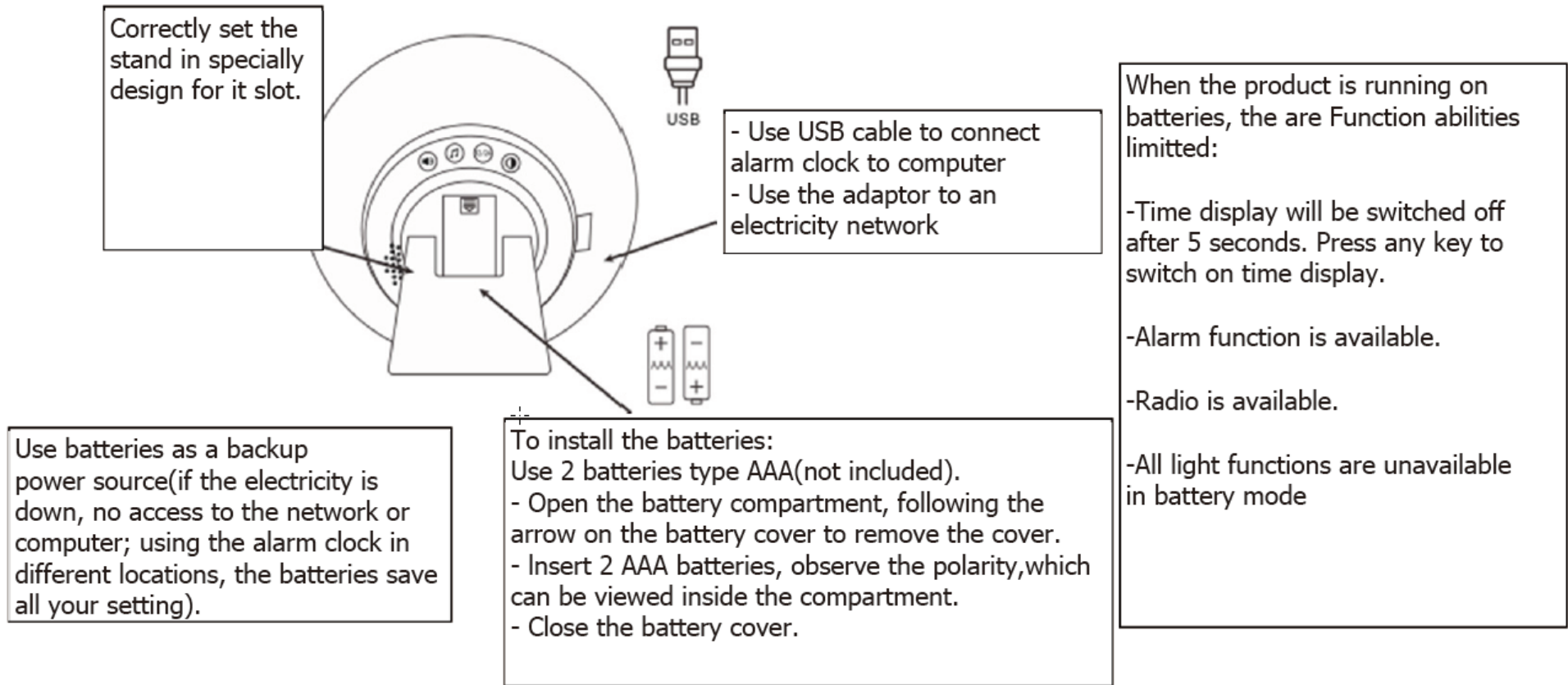

EN	NO
Correctly set the stand in specially design for it slot.	Sett stativet riktig i spesialdesign for sporet.
- Use USB cable to connect alarm clock to computer	- Bruk USB-kabel for å koble vekkerklokken til en datamaskin
- Use the adaptor to an electricity network	- Bruk adapteren til et strømnnett
Use batteries as a backup power source (if the electricity is down, no access to the network or computer; using the alarm clock in different locations, the batteries save all your setting)	Bruk batterier som backup strømkilde (hvis strømmen er nede, ingen tilgang til nettverket eller datamaskinen, ved bruk av vekkerklokken på forskjellige steder, lagrer batteriene alle dine innstillinger)
To install the batteries:	Installere batterier:
Use 2 batteries type AAA (not included).	Bruk 2 batterier type AAA (ikke inkludert).

- Open the battery compartment, following the arrow on the battery cover to remove the cover.	- Åpne batterirommet, følg pilen på batteridekselet for å fjerne dekselet.
- Insert 2 AAA batteries, observe the polarity, which can be viewed inside the compartment.	- Sett inn 2 AAA batterier, observere polariteten, som kan sees inne i rommet.
- Close the battery cover.	- Lukke batteridekslet.
When the product is running on batteries, they are Function abilities limited:	Når produktet kjører på batterier, er funksjonene begrenset:
- Time display will be switched off after 5 seconds. Press any key to switch on time display.	- Tidsvisning vil bli slått av etter 5 sekunder. Trykk på en hvilken som helst tast for å slå på tidsvisning.
- Alarm function is available.	- Alarmfunksjon er tilgjengelig.
- Radio is available.	- Radio er tilgjengelig.
- All light functions are unavailable in battery mode	- Alle lysfunksjoner er utilgjengelige i batterimodus

### **Setting current time**

When the power is connected, the hours indication starts to blink

Hours Setting:

Use  $\oplus$   $\ominus$  to adjust hour

To confirm press 

Minute Setting:

Use  $\oplus$   $\ominus$  to adjust minute

To confirm press 

If the indication is stopped touch  again.



### **12H-24H-format**

Press  key to switch the time format between 12H and 24H

12H

AM or PM will appear on time display.



### **Changing current time**

Touch  button

The hours indication starts to blink.

Hours Setting:

Use  $\oplus$   $\ominus$  to adjust hour

To confirm press 

Minute Setting:

Use  $\oplus$   $\ominus$  to adjust minute.

To confirm press 

If the indication is stopped touch  again.

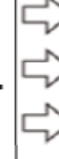

### **Intensity of time display**

Press  key to select the display intensity











Low





















HIGH



OFF



EN	NO
<b>Setting current time</b>	<b>Stille inn tiden</b>
When the power is connected, the hours indication starts to blink	Når strømmen er tilkoblet, begynner timevisningen å blinke
Hours Setting:	Time Innstilling:
Use $\oplus$ $\ominus$ to adjust hour	Bruk $\oplus$ $\ominus$ til å justere time
To confirm press 	For å bekrefte trykk 
Minute Setting:	Minutt Innstilling:
Use $\oplus$ $\ominus$ to adjust minute	Bruk $\oplus$ $\ominus$ for å stille minutt
To confirm press 	For å bekrefte trykk 
If the indication is stopped touch  again.	Hvis indikasjonen er stoppet, trykk på  igjen.
<b>12H-24H-format</b>	<b>12T-24T-format</b>
Press  key to switch the time format between 12H and 24H	Trykk på  tasten for å bytte tidsformat mellom 12H og 24H
12H AM or PM will appear on time display.	12H AM eller PM vises på tidsvisning.
<b>Changing current time</b>	<b>Endre nåværende tid</b>

Touch  button	Trykk på  knappen
The hours indication starts to blink.	Timevisningen begynner å blinke.
Hours Setting:	Time Innstilling:
Use   to adjust hour	Bruk   til å justere time
To confirm press 	For å bekrefte trykk 
Minute Setting:	Minutt Innstilling:
Use   to adjust minute.	Bruk   til å justere minutt.
To confirm press 	For å bekrefte trykk 
If the indication is stopped touch  again.	Hvis indikasjonen er stoppet, trykk på  igjen.
<b><i>Intensity of time display</i></b>	<b><i>Intensitet av tidsvisning</i></b>
Press  key to select the display intensity	Trykk på  tasten for å velge skjermintensiteten
LOW	LAV
<b>HIGH</b>	<b>HØY</b>
OFF	AV

### **Lys-simulering av soloppgang**



Når alarmtiden er innstilt, vil oppvåkingslyset slå seg på 30 minutter før alarmtiden i lav lysstyrke og gradvis øke lysstyrken. På alarmtiden vil lysstyrken være full. Den naturlige lyden eller radioen spilles i 2 minutter på alarmtiden.

Under oppvåkning spiller alarmen



- Trykk på  knappen for å pause alarmen i 5 minutter. Etter 5 minutter vil alarmen spilles igjen i 2 minutter. Trykk på hvilken som helst knapp, unntatt  for å stoppe lyden.
- Trykk og hold  for å slå av oppvåkingslyset.

**FM Radio**  
 Touch  button to turn on/off. Press and hold button for 3 seconds to auto scan.

All available FM channels will be scanned and saved automatically.

Touch  to select an FM station.  
 Press  key to choose volume level 1-15.  
 Note: time display isn't indicated when Radio is turned on.





**Setting the alarm wake-up time**  
 Touch  button to switch on/off alarm mode.  
 symbol appears/disappears on clock display.





Press and hold  button to set alarm.



The hours indication starts to blink.

Hours Setting:  
 Use  to adjust hour.  
 To confirm press

Minute Setting:  
 Use  to adjust minute.  
 To confirm press











If the indication is stopped touch  again.



**Nature sounds**  
 Press  key to select the alarm sound  
 Use  to select 1-7 sounds. Press  to confirm selection.

Each sound (1-6) will play 5 sec before you choose.

When 7 is selected the last played radio station will be played as wake up sound  
 Press  Key to select volume level 00-15

EN	NO
<b>FM Radio</b>	<b>FM Radio</b>
Touch  button to turn on/off. Press and hold button for 3 seconds to auto scan.	Trykk på  knappen for å slå på/av. Trykk og hold inne knappen i 3 sekunder for automatisk skanning.
All available FM channels will be scanned and saved automatically.	Alle tilgjengelige FM-kanaler blir skannet og lagret automatisk.
Touch  to select an FM station.	Trykk på  for å velge en FM-stasjon.
Press  key to choose volume level 1-15.	Trykk på  tasten for å velge volumnivå 1-15.
Note: time display isn't indicated when Radio is turned on.	Merk: Tidsvisning er ikke indikert når Radio er slått på.
<b>Setting the alarm wake-up time</b>	<b>Stille inn alarmtiden</b>
Touch  button to switch on/off alarm mode.	Trykk på  knappen for å slå på/av alarmmodus.
 symbol appears/disappears on clock display.	 symbolet vises/forsvinner på klokkevisning.
Press and hold  button to set alarm.	Trykk og hold nede  for å stille inn alarm.
The hours indication starts to blink.	Timevisningen begynner å blinke.

Hours Setting:	Time Innstilling:
Use ⊕⊖ to adjust hour.	Bruk ⊕⊖ til å justere timen.
To confirm press	For å bekrefte trykk
Minute Setting:	Minutt Innstilling:
Use ⊕⊖ to adjust minute.	Bruk ⊕⊖ til å justere minutt.
To confirm press	For å bekrefte trykk
If the indication is stopped touch ⏏ again.	Hvis indikasjonen er stoppet, trykk på ⏏ igjen.
<b>Nature sounds</b>	<b>Natur lyder</b>
Press 🎵 key to select the alarm sound	Trykk på 🎵 tasten for å velge alarmlyden
Use ⊕⊖ to select 1-7 sounds. Press 🎵 to confirm selection.	Bruk ⊕⊖ til å velge 1-7 lyder. Trykk 🎵 for å bekrefte valget.
Each sound (1-6) will play 5 sec before you choose.	Hver lyd (1-6) vil spille 5 sekunder før du velger.
When 7 is selected the last played radio station will be played as wake up sound	Når 7 er valgt, vil den sist spilte radiostasjonen bli spilt som våkne lyd
Press 🔊 Key to select volume level 00-15	Trykk på 🔊 tasten for å velge volumnivå 00-15

### Setting the Sunset time

Touch ☀️ to switch on/off sunset mode

☀️/🌙 symbol appears/disappears on time display.

Press and hold ⏏ to set  
The hours indication starts to set.

Hours Setting:

Use ⊕⊖ to adjust hours. To confirm press ☀️

minute setting:

Use ⊕⊖ to adjust minute. To confirm press ☀️



### Light

Touch ☀️ to switch on the light

Use ⊕⊖ to adjust the level (1-10) of the brightness

Second touch of ☀️ will switch on automatic color changing mode

Use ⊕⊖ to select color: Green, Red, Blue, Purple, Orange, Indigo

Third touch ⊕⊖ to switch off the light

EN































### Setting the Sunset time

Touch ☀️ to switch on/off sunset mode ☀️/🌙 symbol appears/disappears

NO

### Innstilling av tidspunktet for solnedgang

Trykk ☀️ for å slå på/av solnedgangsmodus ☀️/🌙 symbolet

on time display.	vises/forsvinner på tidsvisning.
Press and hold  to set	Trykk og hold  for å stille inn
The hours indication starts to set.	Timevisningen begynner å stilles inn.
Hours Setting:	Time Innstilling:
Use   to adjust hours. To confirm press 	Bruk   til å justere timer. For å bekrefte trykk 
minute setting:	minutt innstilling:
Use   to adjust minute. To confirm press 	Bruk   til å justere minutt. For å bekrefte trykk 
<b>Light</b>	<b>Lys</b>
Touch  to switch on the light	Trykk på  for å slå på lyset
Use   to adjust the level (1-10) of the brightness	Bruk   til å justere nivået (1-10) på lysstyrken
Second touch of  will switch on automatic color changing mode	Andre trykk på  vil slå på automatisk fargeskiftemodus
Use   to select color: Green, Red, Blue, Purple, Orange, Indigo	Bruk   til å velge farge: Grønn, rød, blå, lilla, oransje, indigo
Third touch   to switch off the light	Tredje trykk på   slår av lyset



## Lys-simulering av solnedgang

 30 min før solnedgangstid, er lyset slått på med 100 % lysstyrke og deretter reduseres lysstyrken gradvis og vil slå av ved solnedgangstidspunktet.

Under solnedgang er lyset slått på, og du kan: Trykke og holde  for å slå av lyset.

## Beskrivelse

- \* Led tidsvisning i 12T-24T-format
- \* Lys-simulering for oppvåkning av soloppgang
- \* Lys-simulering av solnedgang
- \* 6 Natur lyder å våkne opp til
- \* Nattbordlampe
- \* Hvit lysstrøm: 73LM
- \* 10 nivåer for lysstyrken
- \* 6 farget lys + hvitt lys
- \* Automatisk endring av fargelys
- \* FM radio med antenne
- \* 15 volumnivåer
- \* Berøringsmodus
- \* Strømforsyning: DC 5V; 2xAAA batterier; USB kabel.

Merk: Når batteriet er lavt, kan det hende at produktet ikke fungerer riktig.

Bytt ut batteriet med et nytt batteri.



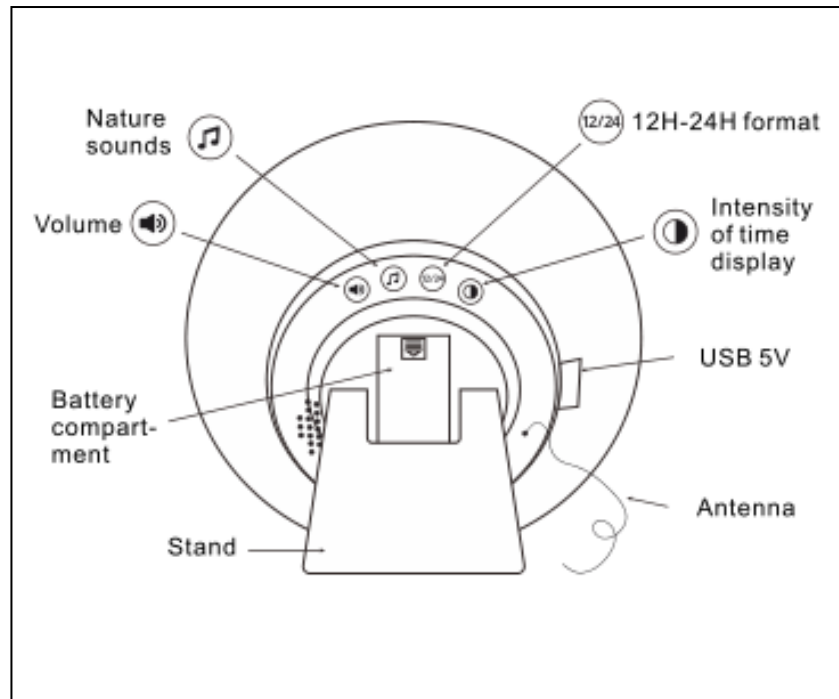
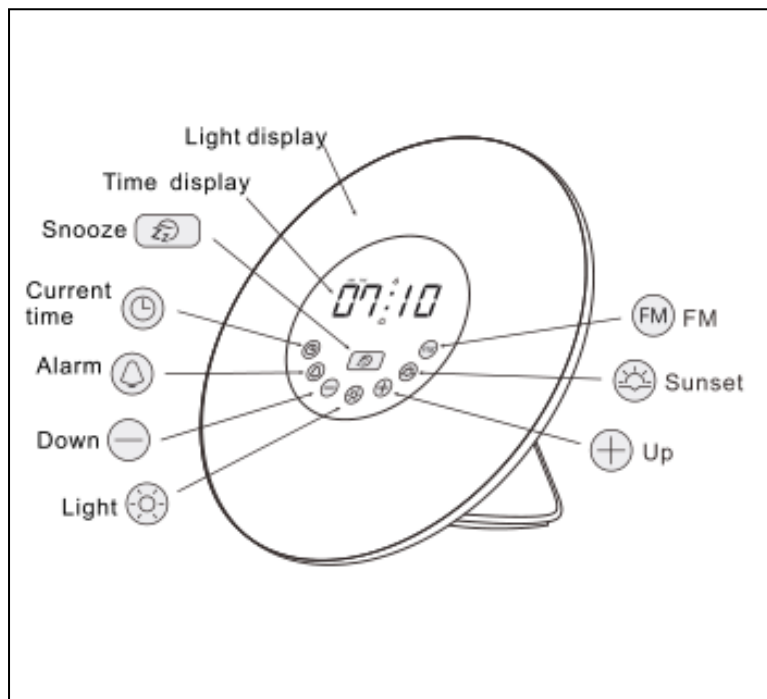

EN	NO
Light display	Lys display
Time display	Tidsvisning
Snooze	Slumre
Current time	Nåværende tid
Alarm	Alarm
Down i	Ned i
Light	Lys
FM	FM
Sunset	Solnedgang
Up	Opp
Nature sounds	Natur lyder
Volume	Volum
Battery compartment	Batterirom
Stand	Stativ
12H-24H format	12H-24H format
Intensity of time display	Intensitet av tidsvisning

USB 5V	USB 5V
Antenna	Antenne



## Advarsel

- \* Ikke trykk på to eller flere taster samtidig
- \* For å unngå feilintervall på hver berøring må hver berøring vare i mer enn 1 sekund.
- \* Hvis det oppstår feil, trekk ut støpselet i 3 sekunder.
- \* Hvis batteriene ikke brukes i lang tid, må du fjerne batteriet.
- \* Når batterispenningen er lav, vil produktet bli startet på nytt og alle innstillinger går tapt. Bytt batteriene.
- \* Adapteren er kun beregnet for bruk med dette produktet. Ikke bruk adapteren for å lade andre enheter som f.eks. mobiltelefon.



## Advarsel

MED ENERETT, OPPHAVSRETT DENVER ELECTRONICS A/S

# DENVER®

www.denver-electronics.com



Elektrisk og elektronisk utstyr inneholder materialer, komponenter og stoffer som kan være farlig for din helse og for miljøet, hvis materialet (kassert elektrisk og elektronisk utstyr) ikke håndteres riktig.

Elektrisk og elektronisk utstyr er merket med en søppelbøtte med kryss over, som vist ovenfor. Dette symbolet betyr at elektrisk og elektronisk utstyr ikke skal kastes sammen med husholdningsavfall, men håndteres separat.

Alle byer har opprettet innsamlingspunkter, hvor elektrisk og elektronisk utstyr kan enten leveres inn gratis på resirkuleringsstasjoner og innsamlingspunkter, eller samles inn fra husholdninger. Mer informasjon er tilgjengelig hos lokale tekniske avdelinger.

Importert av:

DENVER ELECTRONICS A/S

Omega 5A, Soefte

DK-8382 Hinnerup

[www.facebook.com/denverelectronics](https://www.facebook.com/denverelectronics)